

VDU
VMU
Oil burners fuel unit

Oil burners fuel unit

Type VDU and VMU

DELTA fuel unit VDU and VMU are pumps for oil burners or transfer systems, designed to replace DELTA units V, VD and VM with limited modifications.

Description

VDU fuel unit consists of a filter (1), a pumping gear (2) and a pressure regulator (3). VMU unit is additionally equipped with a solenoid valve (4).

Nozzle port is present on both sides (5).

Pressure (6) and vacuum (7) ports are present in front cover.

VDU and VMU units are available in two-pipe or one-pipe version. Both versions are self priming. The pump can be converted from version to the other in few steps.

These units are suitable for oil with a maximum biodiesel content of 10%. With higher biodiesel percentage, "B" version with special seals is recommended. These units must not be used with water or acid.

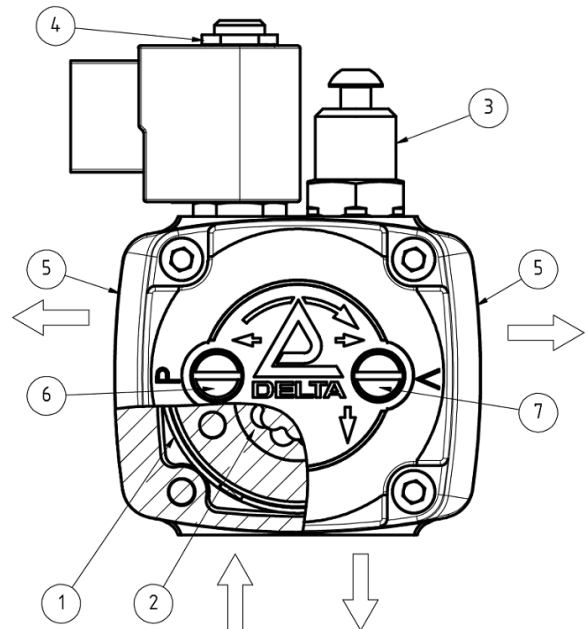

Pump specifications

Oil viscosity	1,2 ÷ 12 cSt If fuel viscosity is lower than 2.5cSt (i.e. Kerosene), pressure must be lower than 12 bar.
Oil temperature	60°C max.
Suction line vacuum	0,5 bar max
Suction line pressure	2 bar max
Return line pressure	2 bar max
Rotation speed	3500 rpm max
Standard strainer	Nylon mesh 150µ, V..1 with 9cm², V..2 ÷ V..5 with 20cm² Hub Ø32, shaft Ø8
Dimensions (EN 225)	(optional: hub Ø54 with adapting ring or flanged connection with holes Ø10x92)
Connections (ISO 228/1)	Inlet – Return: G1/4" Nozzle (2x) / pressure / vacuum ports: G1/8"
Weight	gr. 1100

Valve specifications

Power absorbed	9 W
Voltage tolerance	-15% / +10%
Environment temperature	0°C / 60°C
Working pressure	25 bar max.
Flow factor (VDI/VDE 2173)	0,059 m³/h
Cut-off pressure	2 bar
Standards	EN ISO 23553-1
Coil specifications	Type NF84 (coil with connector plug) - Voltage available: 230V 50-60Hz, 110V 50-60Hz, 24V 50-60Hz, 24V DC, 12V DC Cable to be ordered separately, length 700mm

Nozzle capacity

Power consumption

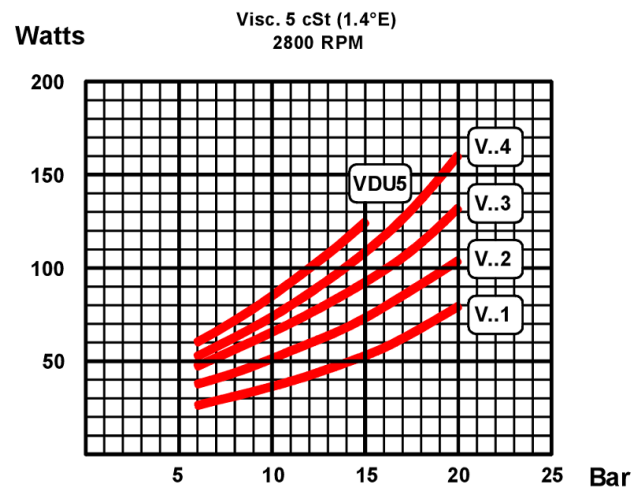
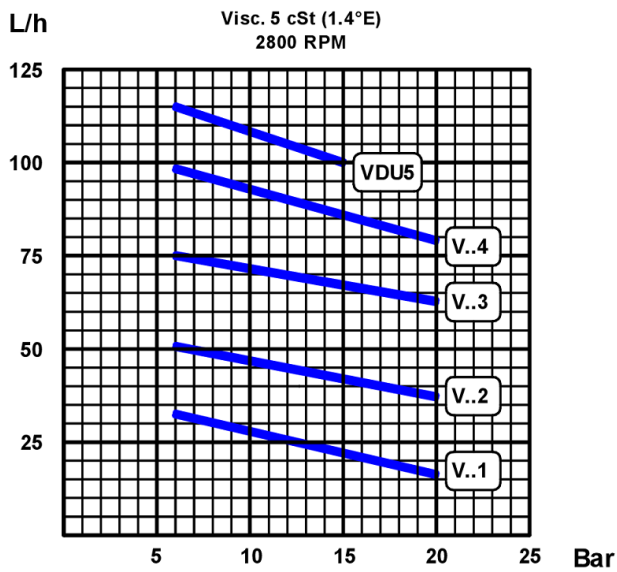

Dimensions and connections

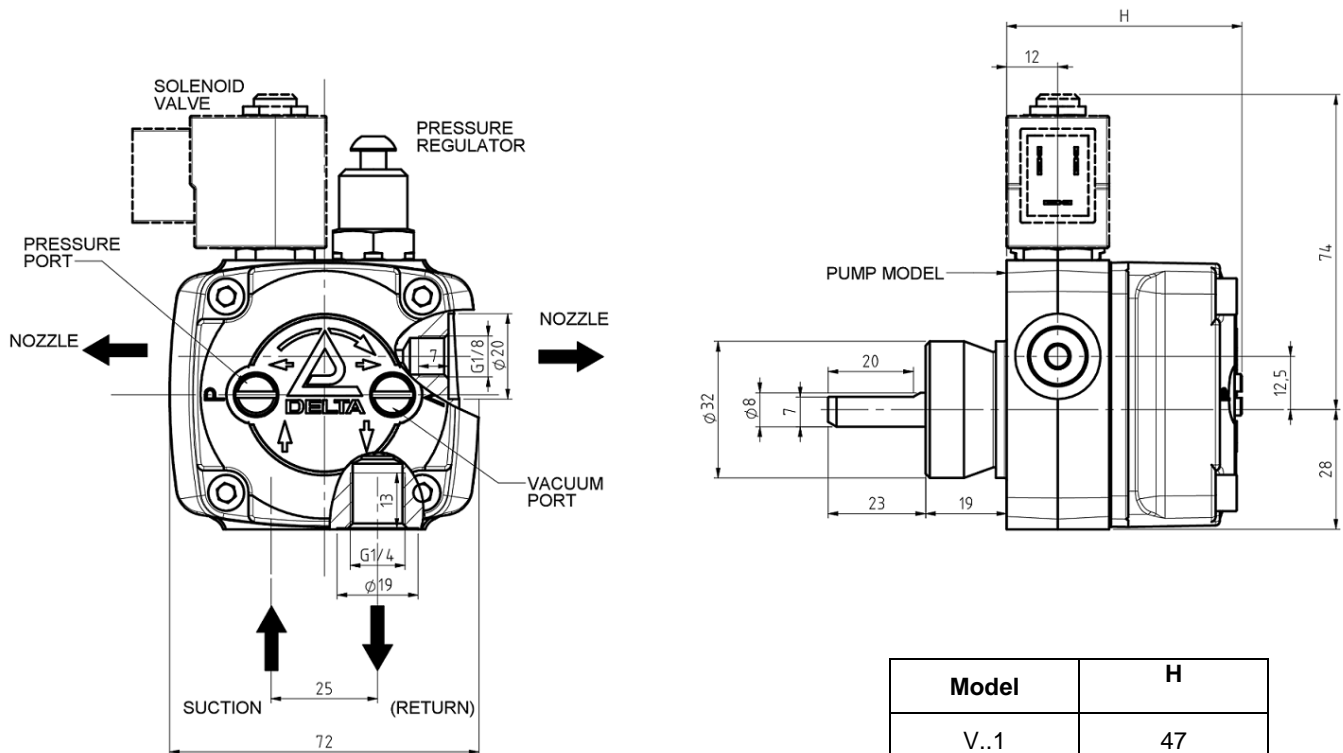

Model	H
V..1	47
V..2	55
V..3	55
V..4	55
VDU5	57

Note:
Adapting ring $\phi 54/32$ or flange with holes $\phi 10 \times 92$ has to be ordered separately.

Model identification

	VMU	3	R	2	4	FA
Pump type VDU gear pump for oil burner VMU gear pump for oil burner with solenoid valve						
B prefix for biodiesel version						
Nozzle capacity @10bar (*) 1 = 27 Lt/h 2 = 45 Lt/h 3 = 70 Lt/h 4 = 90 Lt/h 5 = 105 Lt/h (only for VDU type)						
Rotation (seen from shaft end) R = clockwise L = counter clockwise						
Pipe Version 1 = one pipe 2 = two pipes						
Pressure ranges 3 = 2 ÷ 7 bar 4 = 6 ÷ 18 bar (standard)						
						Factory setting 4 ±0,3 bar 10 ±0,5 bar
Voltage of solenoid valve – only for VMU type FA = 230 VAC FC1 = 24 VDC FB = 110 VAC FD = 12 VDC FC = 24 VAC						

(*) Reference value, see paragraph above for details.

Installation

CAUTION: before servicing any part of the system, turn off all power and shut off oil at manual valve.

1- Check that pump model complies with features of your system. If necessary, pump can be converted from one-pipe to two pipe version and vice versa, see paragraph below for this purpose.

2- Use the correct joint between motor and pump.

3- Insert the pump hub in the motor housing.

4- Screw the radial blocking screws progressively, taking care of not forcing the pump shaft along its axis or laterally to avoid excessive wear on the joint and noise.

5- Pay attention to solenoid valve: do not use it as lever.

6- Connect pipes, paying attention that:

- an external filter should always be installed in the suction line upstream of the fuel unit (pump filter is not meant to be a main filter so it can get clogged in short time if main upstream filter is absent);
- pipes should not contain air pockets. The number of junctions should be as minimum as possible and rapid attachment joint should be avoided;
- use O-Rings or mechanical seal (copper or aluminium gaskets) junctions if possible;
- avoid overtightening: G1/8" → 15 Nm max;
G1/4" → 20 Nm max;
- do not use PTFE tape on the suction and nozzle pipes. Particles of PTFE could deposit on filter or in nozzle, reducing efficiency;
- when junction threads, elbow joints and couplings are sealed with glue, avoid excessive quantities, which could enter in the pump and damage it;

- 7- Make sure the combustion chamber is free of oil or oil vapor before operating the system.
- 8- On initial commissioning, if there is a long suction line to bleed, inject some lubrication oil into the vacuum port before turning on the motor.
- 9- After filling the tank, wait some hours before switching the burner on, so that impurities will deposit and pump will not suck them. Do not add additives to fuel to avoid formation of compounds which may block the pump.
- 10- After turning the motor on, set the correct nozzle pressure as described in paragraph below.
- 11- If necessary, vacuum test and nozzle cut-off tests can be performed.

Nozzle Pressure Setting

Most nozzles ratings are based upon 100psig (7bar) oil pressure. The flow rate at the desired nozzle pressure must be estimated using the nozzle manufacturers data sheets.

To ensure that oil is delivered to the burner nozzle at the desired pressure, proceed as follows:

- 1- with motor turned off, remove the 1/8" plug from the port marked "P" and connect a pressure gauge to this port (use a gauge 0 - 20bar or higher).
- 2- Start the burner motor, energize the solenoid valve and vent all air from the fuel unit.
- 3- Check the nozzle pressure of the fuel unit and, using a 4 mm Allen wrench, adjust the nozzle pressure at desired level: turning the adjusting screw counter-clockwise to lower and clockwise to increase the nozzle pressure.

CAUTION: during this setting, fuel is sprayed, if combustion is absent, a potentially explosive atmosphere is present. Pay attention not to ignite this atmosphere: evacuate it as soon as possible.

Vacuum Test

Vacuum test is useful to verify fuel unit suction ability, to evaluate the leak tight integrity of the entire suction line piping and to confirm that the system vacuum is within the allowable specification limits of the unit.

To perform the test, proceed as follows:

- 1- Remove the 1/8" plug from the port marked "V" and connect a vacuum gauge to this port.
- 2- Start the burner motor and vent all air from the fuel unit and connected suction line system.
- 3- With the burner motor running, close the manual valve connected to the inlet port: vacuum measured by the gauge will increase. Allow the burner motor to continue to run until the highest vacuum reading is achieved. A fully primed fuel unit in good condition should be capable of pulling at least -0.7bar. If not, before condemning the fuel unit, be sure that all connections and plugs are tight, the cover gasket and the manual valve are in good conditions.
- 4- With VMU type de-energize the solenoid valve and shut off the burner motor. Initially, the vacuum reading will drop and then stabilize within a second or two. Once the vacuum reading stabilizes, record the reading. If the fuel unit is free of leaks, this reading should hold constant for at least 2 minutes. If the vacuum reading drops, there is a leak that must be detected and fixed.
- 5- When each leakage is fixed and the valve onto suction line is open, check to be sure that the current operating vacuum does not exceed -0.5bar.

Nozzle Cut-Off Test (*VMU type only*)

Fuel oil is not compressible but air is. Air trapped in the nozzle line will compress during burner operation; after burner shutdown, trapped compressed air will expand forcing an oil flow through the nozzle that will appear as incorrect Cut-Off of the unit. This occurrence is particularly common with low flow rate nozzles and long nozzle pipe.

To verify good nozzle Cut-Off after burner shutdown, proceed as follows:

- 1- Remove the nozzle line from fuel unit and connect a 1/8" pressure gauge to the nozzle port (a gauge of 20bar or higher has to be used). It may be more convenient to use a gauge fitted out with an extension nipple or with a line and flare nut to connect directly to the fitting installed into the nozzle port. If any type of extension is used between the nozzle port and the gauge, it should be kept as short as possible to minimize the amount of trapped air.
- 2- Start the burner motor, energize the solenoid valve and vent all air from the fuel unit and connected suction line system.
- 3- Shut off the burner motor. Initially the pressure will drop and then stabilize within some seconds. The pressure reading on the gauge should stabilize at 2 bar or higher and hold for at least two minutes. If pressure fall under 2 bar, probably shut-off valve is dirty: remove the coil and unscrew the stem to clean the rubber seal. When reassembling the valve, pay attention to assemble all parts correctly. It is possible to replace the mechanical parts of solenoid valve.

CAUTION: the VDU type does not perform any cut-off action. An external solenoid valve must be installed in the nozzle line.

Maintenance

If pump has not worked for several months, it can be blocked: remove it from the motor and try to turn manually the shaft (pay attention not to damage the shaft with improper tool). Then reassemble pump and motor.

At least once a year pump filter has to be cleaned: remove the cover, remove the round filter and clean it with compressed air. Reassemble filter around the gear, pay attention that supporting legs are leaned against pump body. If the gasket between cover and pump housing is damaged, it must be replaced.

One pipe - two pipe conversion

To convert the DELTA fuel unit from one-pipe version to two pipe version, do the following:

- 1- Using a 19 mm hex wrench, remove the G1/4" return plug from return port (Fig. 1).
- 2- Inner side of return plug stores the by-pass bush. Remove the bush with a 4 mm Allen wrench (Fig.2).
- 3- Insert and tighten the by-pass bush in the return port (Fig. 3).

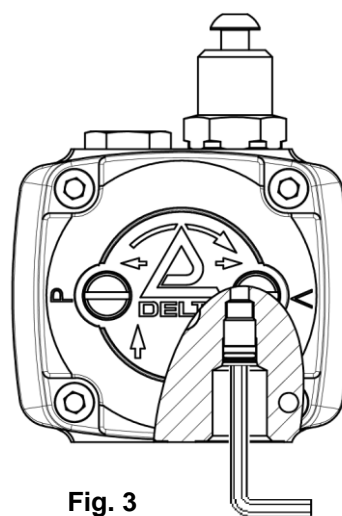
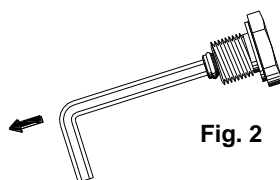
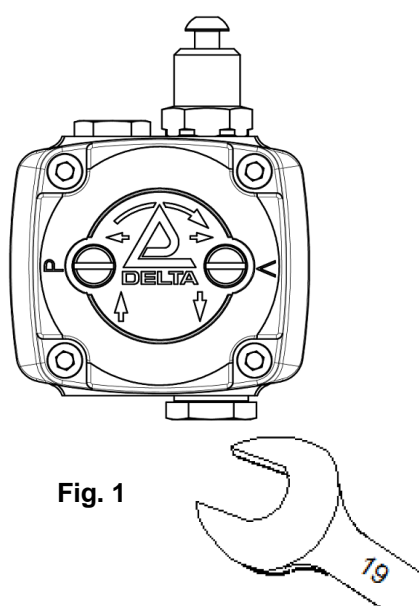

To convert the DELTA fuel unit from two pipe version to one pipe version, do the following:

- 4- Using a 4 mm Allen wrench, unscrew the by-pass bush from the return port (Fig. 3).
- 5- Screw a G1/4" plug with seal into the return port (Fig. 1).

WARNINGS

- After conversion, air must be bled manually, through the pressure port onto the cover.
- Make sure that the by-pass plug is not present in a single pipe installation, because the fuel unit will not function properly and damage to the pump and burner could result.

The information in this document contains general descriptions of technical options available and based on current specifications.

Copyright © 2023 - All rights reserved.

DELTA is a brand name of: Elettromeccanica Delta S.p.A.
Via Trieste 132
31030 Arcade (TV) – ITALY
Phone +39 0422 874 068
www.delta-elektrogas.com
info@delta-elektrogas.com